

SERIE 400 Linea per ante di legno in linea

SERIES 400 Line for aligned wooden doors



Sistemi scorrevoli per mobili / Sliding systems for furniture

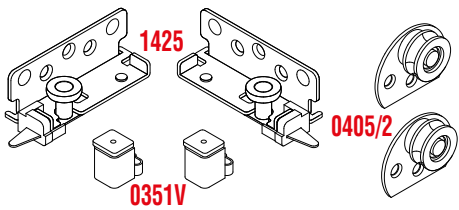

KIT 0405/2-1425 - MAX 30 KG



Legenda KIT / Kit Legend

0405/2	Carrello inferiore con cuscinetto Ø25 <i>Lower truck with ball bearing Ø25</i>
0351V	Fermo inferiore <i>Lower stopper</i>
1425	Guida superiore <i>Upper guide</i>

Legenda altri componenti *Legend other items*

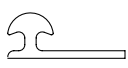
0601		Profilo alluminio superiore <i>Upper aluminium profile</i>
0380		Profilo alluminio inferiore <i>Lower aluminium profile</i>
0300		Profilo alluminio inferiore <i>Lower aluminium profile</i>

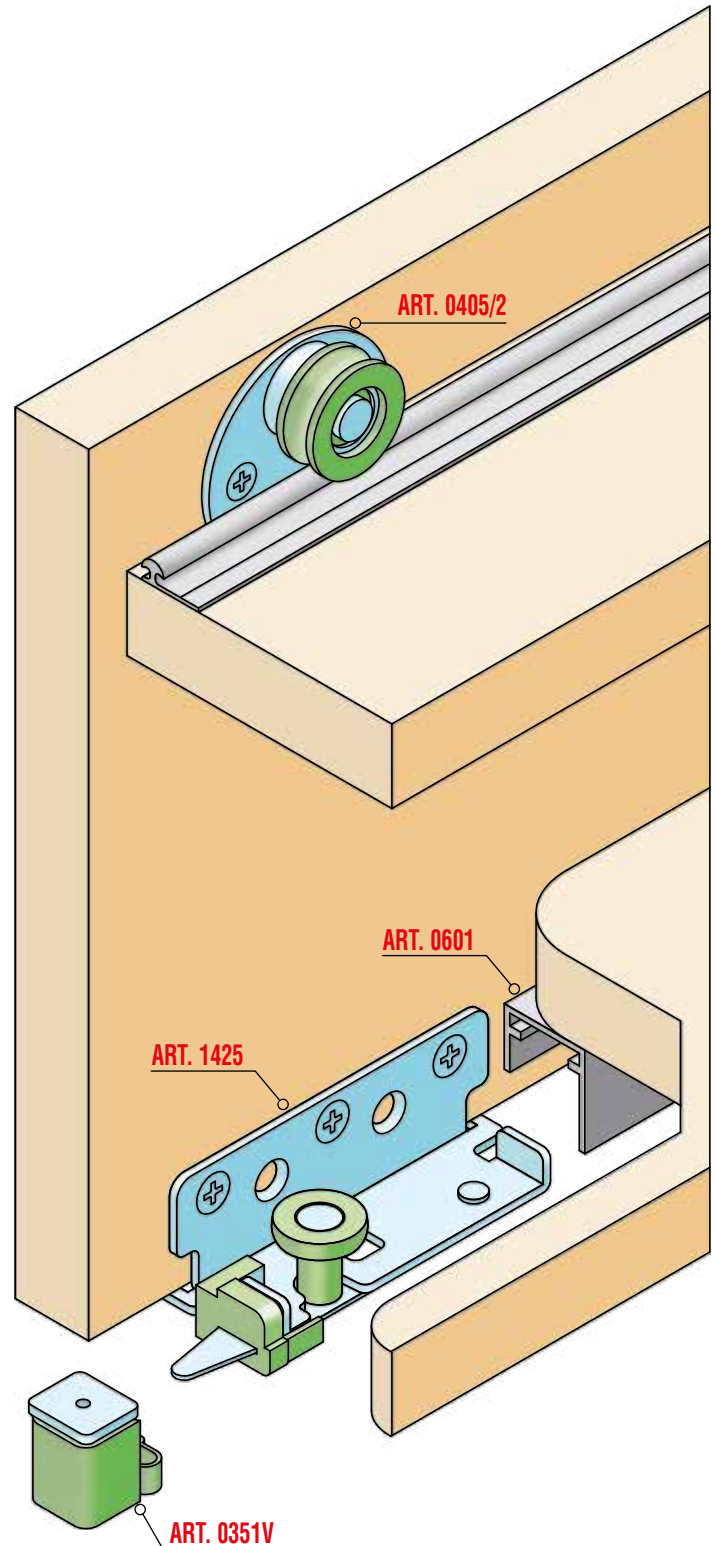

210 Serie 400



Sistemi scorrevoli per mobili / Sliding systems for furniture

Sezione verticale / Vertical section

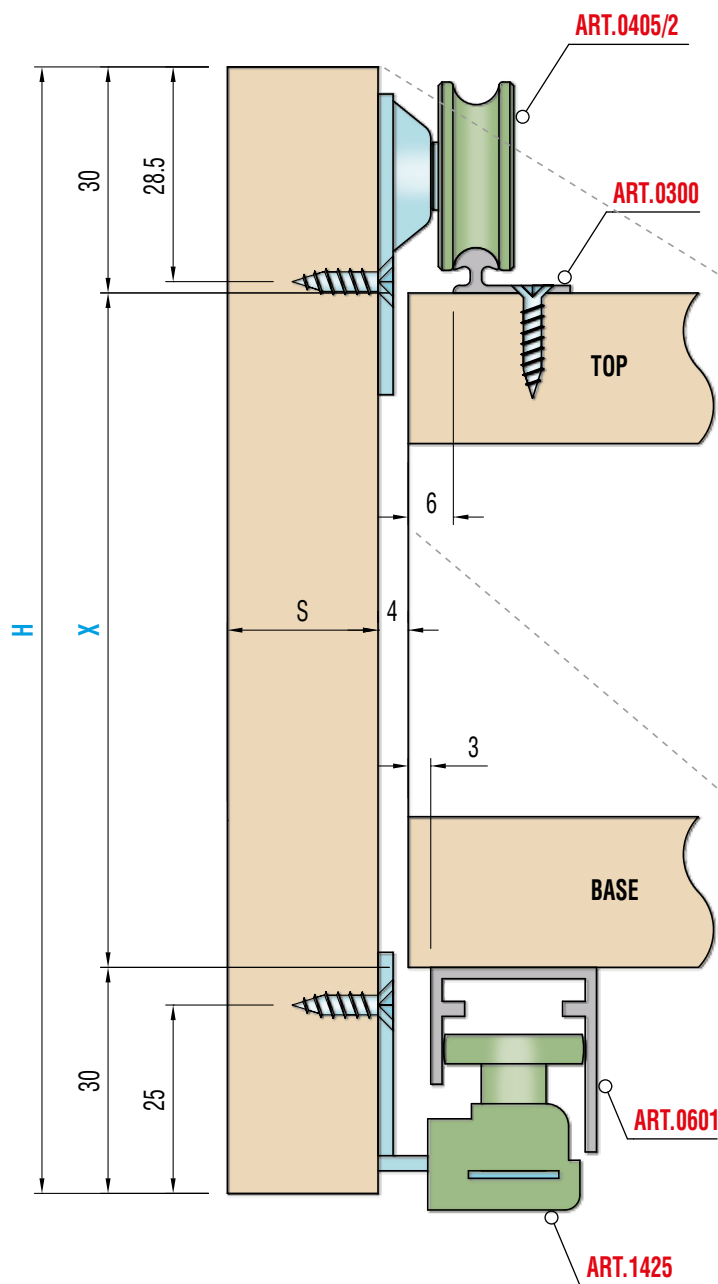

Peso massimo anta Kg. 30
Maximum door weight Kg 30

$$H = X + 60$$

Variante Special version

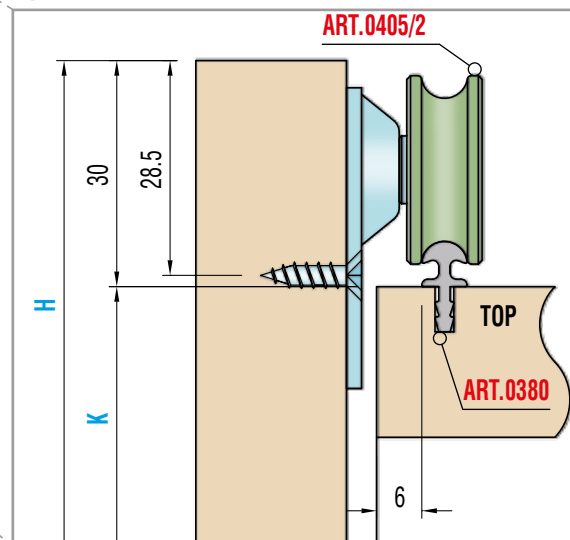

Schema Foratura ante / Doors drilling

